



# USER'S MANUAL

9" COMPACT AMPLIFIED UNDERSEAT SUBWOOFER

## CS9A



*150 Watt*  
PEAK POWER

- |           |      |           |                 |                    |                     |
|-----------|------|-----------|-----------------|--------------------|---------------------|
| 9"        | 150W | 72MM      |                 |                    |                     |
| DIAPHRAGM | RMS  | SLIM BODY | EASY CONNECTION | BUILT-IN CROSSOVER | REMOTE BASS CONTROL |

TRUST THE SOUND TRUST THE SOUND TRUST THE SOUND



# CONTENT

Introduction	4
Precautions	5
Installation	7
Connection	8
Accessory List	13
Specifications	14

# INTRODUCTION

Congratulations on your purchase of FIVE CS9A Compact Underseat Amplified Subwoofer! CS9A has been engineered, designed and manufactured so you can enjoy quality sound for a long time. For installation of this product we recommend contacting professional installers of car audio. Please read the user's manual carefully and throughout before the installation and the first operation of the product. It is recommended to keep this manual in a safe place for further reference.

# PRECAUTIONS

## WARNING!

• **Do not operate any function that takes your attention away from safely driving your vehicle.**  
Any function that requires your prolonged attention should only be performed after coming to a complete stop. Always stop the vehicle in a safe location before performing these functions. Failure to do so may result in an accident.

• **Keep the volume at a level where you can still hear outside noises while driving.**  
Excessive volume levels that obscure sounds such as emergency vehicle sirens or road warning signals (train crossings, etc.) can be dangerous and may result in an accident. Listening at loud volume levels in a car may also cause hearing damage.

• **Do not disassemble or alter.**

Doing so may result in an accident, fire or electric shock.

• **Use this product for mobile 12V applications.**

Use for other than its designed application may result in fire, electric shock or other injury.

• **Use the correct ampere rating when replacing fuses.**

Failure to do so may result in fire or electric shock.

• **Do not block vents or radiator panels.**

Doing so may cause heat to build up inside and may result in fire.

• **Make the correct connections,**

Failure to make the proper connections may result in fire or product damage.

• **Use only in vehicles with a 12 volt negative ground.**

Failure to do so may result in fire, etc. (Check with your seller if you are not sure.)

• **Before wiring, disconnect the cable from the negative battery terminal.**

Failure to do so may result in electric shock or injury due to electrical shorts.

• **Do not allow cables to become entangled in surrounding objects.**

Arrange wiring and cables in compliance with the manual to prevent obstructions when driving.

Cables or wiring that obstruct or hang up on places such as the steering wheel, gear lever, brake pedals, etc. can be extremely hazardous.

• **Do not splice into electrical cables.**

Never cut away cable insulation to supply power to other equipment. Doing so will exceed the current carrying capacity of the wire and result in fire or electric shock.

• **Do not damage pipe or wiring when drilling holes.**

When drilling holes in the chassis for installation, take precautions so as not to contact, damage or obstruct pipes, fuel lines, tanks or electrical wiring. Failure to take such precautions may result in fire,

• **Do not use bolts or nuts in the brake or steering systems to make ground connections.**

Bolts or nuts used for the brake or steering systems (or any other safety-related system), or tanks should NEVER be used for installations or ground connections. Using such parts could disable control of the vehicle and cause fire etc.

• **Keep small objects such as bolts or screws out of the reach of children.**

Swallowing them may result in serious injury. If swallowed, consult a physician immediately.

- **Stop usage immediately if a problem appears.**

Failure to do so may cause personal injury or damage to the product. Return it to your seller or a nearest service center for repairing.

- **Have the wiring and installation done by car audio experts.**

The wiring and installation of this unit requires special technical skill and experience. To ensure safety, it is recommended to contact with professional car audio experts to have the installation and wiring work done.

- **Use specified accessory parts and install them securely.**

Be sure to use only the specified accessory parts. Use of other than designated parts may damage this unit internally or may not securely install the unit in place. This may cause parts to become loose resulting in hazards or product failure.

- **Arrange the wiring so it is not crimped or pinched by a sharp metal edge.**

Route the cables and wiring away from moving parts (like the seat rails) or sharp or pointed edges. This will prevent crimping and damage to the wiring. If wiring passes through a hole in metal, use a rubber grommet to prevent the wire's insulation from being cut by the metal edge of the hole.

- **Do not install in locations with high moisture or dust.**

Avoid installing the unit in locations with high incidence of moisture or dust. Moisture or dust that penetrates into this unit may result in product failure.

# INSTALLATION

## WARNING!

### Caution

Caution on connection terminals/parts

•Keep electrically conductive objects away from the unit's terminals/parts (power terminals, fuses, speaker input terminals, RCA connectors, etc.). Doing so prevents a possible short circuit and damage to the unit.

### Mounting

1. Attach the included mounting brackets to the CS9A with the supplied screws. (at Fig. 1)
2. Once the brackets are mounted to the CS9A. Place the subwoofer in the desired location within the vehicle. Before securing with screws, check to make sure all screws can affix to a structurally solid surface while avoiding vehicle wiring, components, etc. [at Fig.2]

### NOTE

For securing the mounting brackets to the vehicle, it may be necessary to use longer screws (not included) to accommodate carpet thickness, etc. To securely connect the ground lead, use an already installed screw on the metal part of the vehicle (marked this is a good ground by checking continuity to the battery(-) terminal). As much as possible connect all equipment same ground point. These procedures will help eliminate noise.

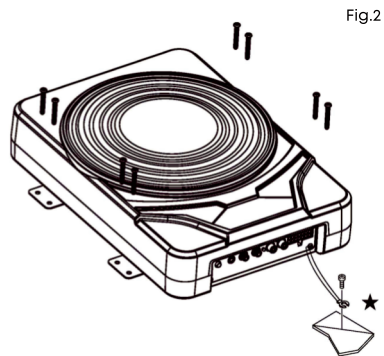
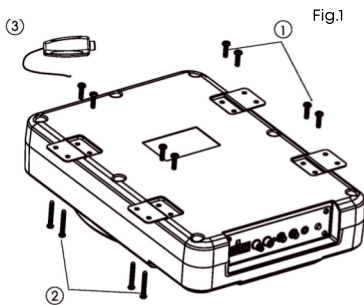

# CONNECTION

Before making connections, be sure to turn the power off to all audio components. Connect the red battery lead from the amp directly to the positive (+) terminal of the vehicle's battery. Do not connect this lead to the fuse block.

## WARNING!

### **Caution on connection terminals/parts**

Keep electrically conductive objects away from the unit's terminals/ parts (power terminals, fuses, speaker output terminals, RCA connectors, etc.). Doing so prevents a possible short circuit and damage to the unit.

To prevent external noise from entering the audio system. Locate the unit and route the leads at least 10 cm (3-15/ 16") away from the car harness. Keep the battery power leads as far away from other leads as possible. Connect the ground lead securely to a bare metal spot (remove any paint or grease if necessary) of the car chassis. Car audio experts know best about noise prevention measures so consult qualified car audio experts for further information.

### **1. Input / Power Connector**

#### **2. RCA Input Jacks**

Connect these jacks to the line out leads on your head unit using RCA extension cables (sold separately).

#### **3. Fuse (15A)**

USE ONLY THE CORRECT AMPERE RATING WHEN REPLACING FUSES.

Failure to do so may result in fire or electric shock.

#### **4. Input / Power Wire Harness**

#### **5. Speaker Input Leads**

These leads are input leads for use with head units not equipped with preamp outputs. When not using the RCA Line Input connectors, you should connect these wires to the speaker output leads of your head unit. The CS9A accepts input from high power or standard power head units.

### **NOTE**

Do not connect speaker leads together or to chassis ground. Use either RCA line level or speaker level inputs. Do not connect both at the same time.

#### **6. Battery Lead (Red)**

Connect battery lead directly to BATT + Be sure to add a 15A fuse (sold separately) as close as possible to the battery's (+) terminal.

#### **7. Remote Turn-On Lead (Blue/White)**

Connect this lead to the remote turn-on (positive trigger, (+) 12V only) lead of your head unit.

#### **8. Ground Lead (Black)**

Connect this lead securely to a clean, bare metal spot on the vehicle's chassis. Verify this point to be true ground by checking for continuity between that point and the negative (-) terminal of the vehicle's battery. Ground all your audio components to the same point on the chassis to prevent ground loops.



### Switch setting

#### 9. Phase switch 0° to 180°

Subwoofer output phase can be set to Subwoofer Normal 0° (Button Out) or Sub woofer Reverse 180° (Button In).

**10. Crossover Frequency Adjustment Knob (LP FILTER)** Use this control to adjust the crossover frequency between 50 to 150Hz.

#### 11. Input Gain Adjustment Control

**NOTE:**

If the Remote Bass Level Knob will be connected in your system, make sure to rotate the knob fully clockwise (set to "+") before making the input gain adjustment.

Set the CS9A input gain to the minimum position. Using a vivid music track as a source, increase the head unit volume until the output distorts. Then, reduce the volume 1 step (or until the output is no longer distorted). Now, increase the amplifier gain until the sound from the speakers becomes distorted. Reduce the gain slightly so the sound is no longer distorted to achieve the optimum gain setting.

#### 12. Power Indicator

Indication Color	Status	Solution
Green	Amplifier circuit is normal	
LED is off	Amplifier circuit is abnormal. An electrical short has occurred, or supply current is too high. 15A fuse may be blown.	Turn off the power supply and eliminate the cause (replace necessary). Then turn on the unit and verify that the LED has turned on. If it remains off, turn off, turn off the unit and consult your seller.
Red	Power supply voltage is too high.	Use the correct power supply voltage.

#### 13. Remote Gain Adjustment Input

Remote Gain Adjustment Knob Allows the user to adjust the overall bass level of the subwoofer. Turning the remote bass level knob towards (+) increases the overall subwoofer level, while turning the bass level knob towards (-) decreases the overall subwoofer level.

**NOTE:**

CS9A can be used without connecting the remote bass level knob. However, overall subwoofer level cannot be adjusted from the listening position.

#### 14. Remote Bass Knob Control

# FIGURE 3

## RCA Input System

F - Head Unit, etc. (sold separately)

G - RCA Cable (sold separately)

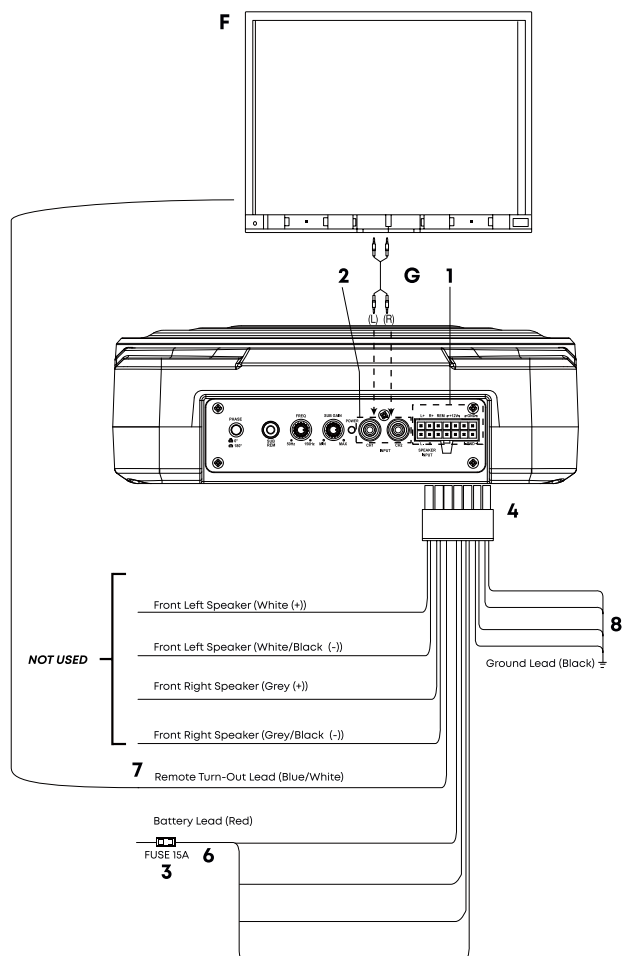

# FIGURE 4

## Speaker level input system

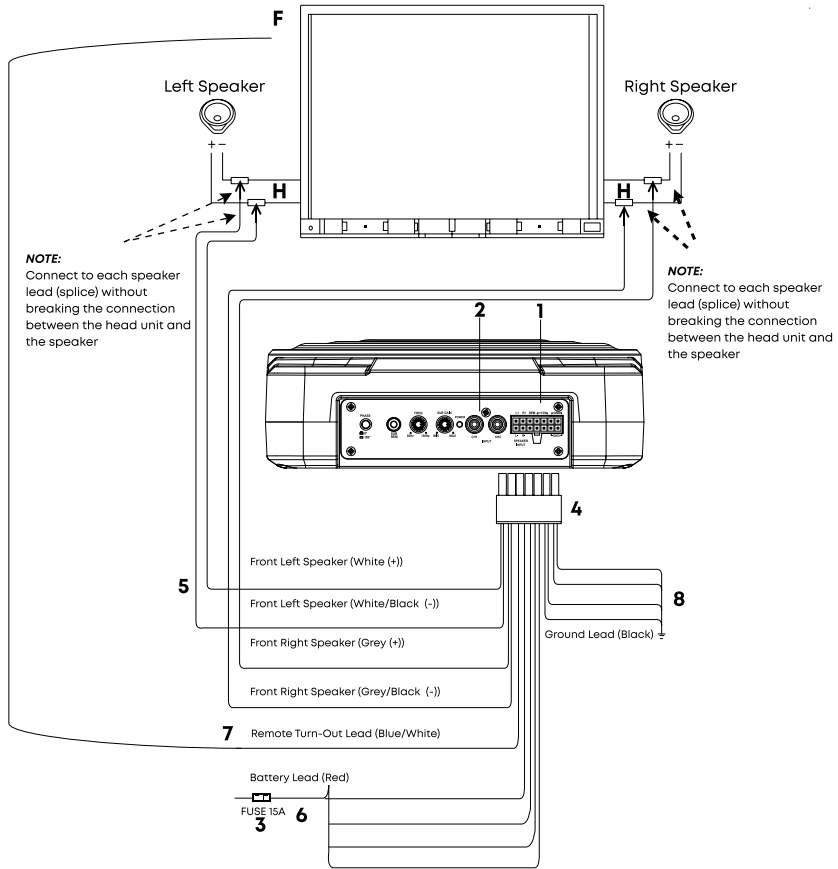

## Connection Panel

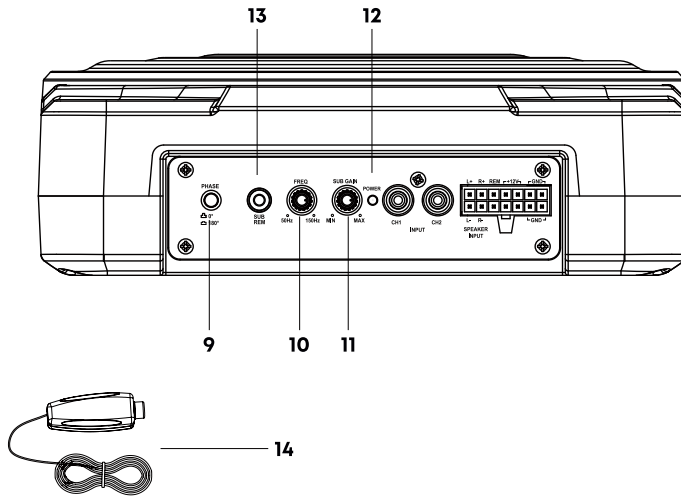

## ACCESSORY LIST

User's Manual	1 pieces
Insert Power Cable	1 piece
Remote Control	1 piece
Bracket	4 pieces
Screws	8 pieces
Brackets Screws	8 pieces

# SPECIFICATIONS

## SOUND

Power Output (RMS)	150 Watts
Frequency Response	34-400Hz

## WOOFER

Diaphragm Size (Nominal)	9 inch
Diaphragm Material	Polypropylene
Surround	Rubber

## AMPLIFIER

Power Output (RMS)	150 watts
Low Pass Crossover	30-150Hz
Input Sensitivity	0.1-5.0V (RCA Input), 0.5-10.0V (Speaker Level Input)

## ACCESSORIES

Remote Knob	Cable Length: 5M, Adjustment Range: 0 to -30dB
-------------	---------------------------------------------------

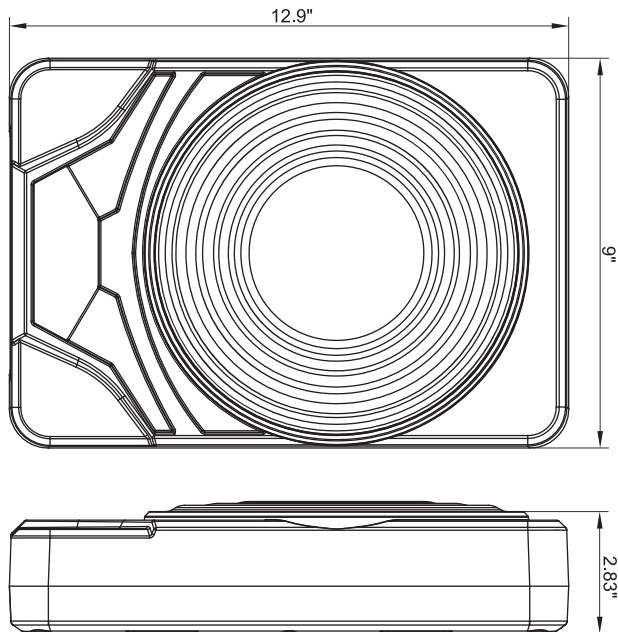

**Safe disposal**

*Your device is designed and made of high quality materials and components that can be recycled and reused. If the product has a crossed-out wheeled bin symbol, this means that the product complies with European Directive 2002/96 / EC. Check out the local separate collection system for electrical and electronic products. Observe local regulations. Dispose of old devices separately from household waste. Proper disposal of your product will help prevent potential negative consequences for the environment and human health.*









"AUTOTEK INDUSTRIAL LIMITED"  
1318-19,13/F, HOLLYWOOD PLAZA, 610 NATHAN ROAD, MONGKOK, KOWLOON,  
HONG-KONG, CHINA

**MADE IN P.R.C.**

---

 TRUST THE SOUND  TRUST THE SOUND  TRUST THE SOUND 

---